



US 20140267460A1

(19) **United States**

(12) **Patent Application Publication**
Bolas et al.

(10) **Pub. No.: US 2014/0267460 A1**
(43) **Pub. Date: Sep. 18, 2014**

(54) **CONTROL OF AMBIENT AND STRAY LIGHTING IN A HEAD MOUNTED DISPLAY**

Publication Classification

(71) Applicants: **Mark Bolas**, Los Angeles, CA (US); **J. Adam Jones**, Seneca, SC (US); **David M. Krum**, Arcadia, CA (US)

(51) **Int. Cl.**
G09G 3/22 (2006.01)
(52) **U.S. Cl.**
CPC **G09G 3/22** (2013.01)
USPC **345/690**

(72) Inventors: **Mark Bolas**, Los Angeles, CA (US); **J. Adam Jones**, Seneca, SC (US); **David M. Krum**, Arcadia, CA (US)

(57) **ABSTRACT**

(73) Assignee: **UNIVERSITY OF SOUTHERN CALIFORNIA**, Los Angeles, CA (US)

A head mounted display (HMD) for viewing a virtual environment generally include a flat display (FD), lenses for focusing on the FD, and a housing to enclose the FD and lenses. The housing is generally opaque to block out all external light, so the viewer only sees light from the FD. By making a portion or all of the housing translucent or transparent, ambient light and other external light can be seen by the viewer, providing additional visual cues and a larger perceived field of view. Additionally, other people can see light from the FD. The lenses are configured to view the FD and parts of the translucent housing.

(21) Appl. No.: **14/216,152**

(22) Filed: **Mar. 17, 2014**

Related U.S. Application Data

(60) Provisional application No. 61/800,866, filed on Mar. 15, 2013.

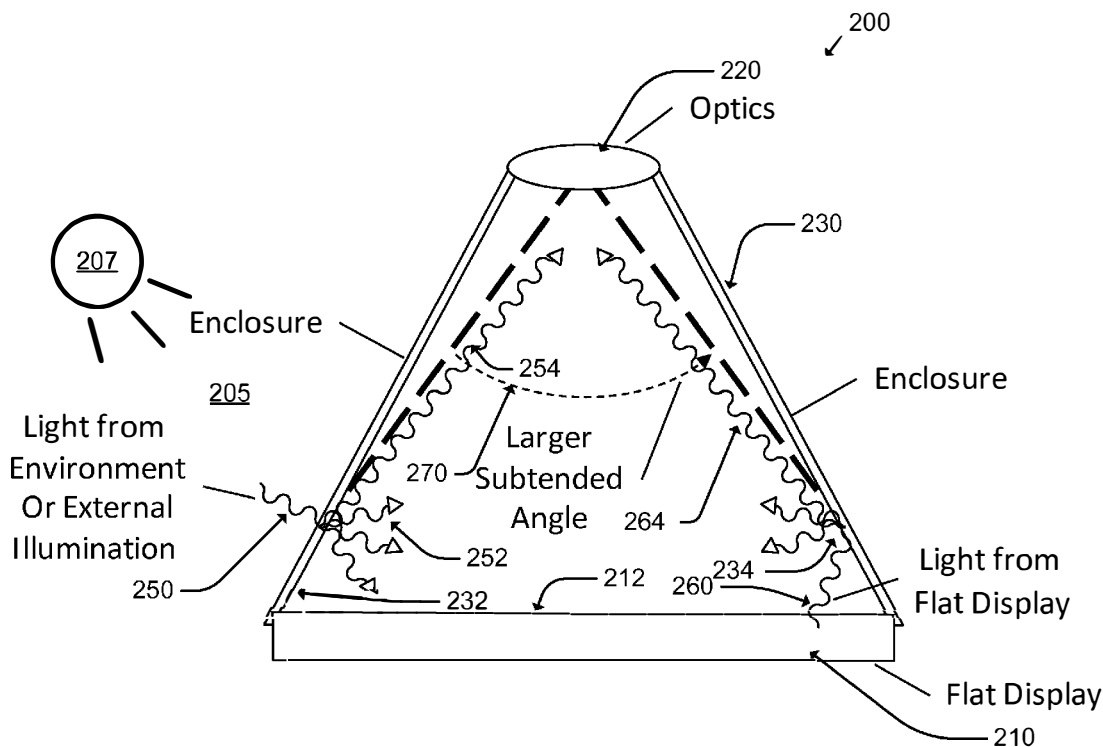

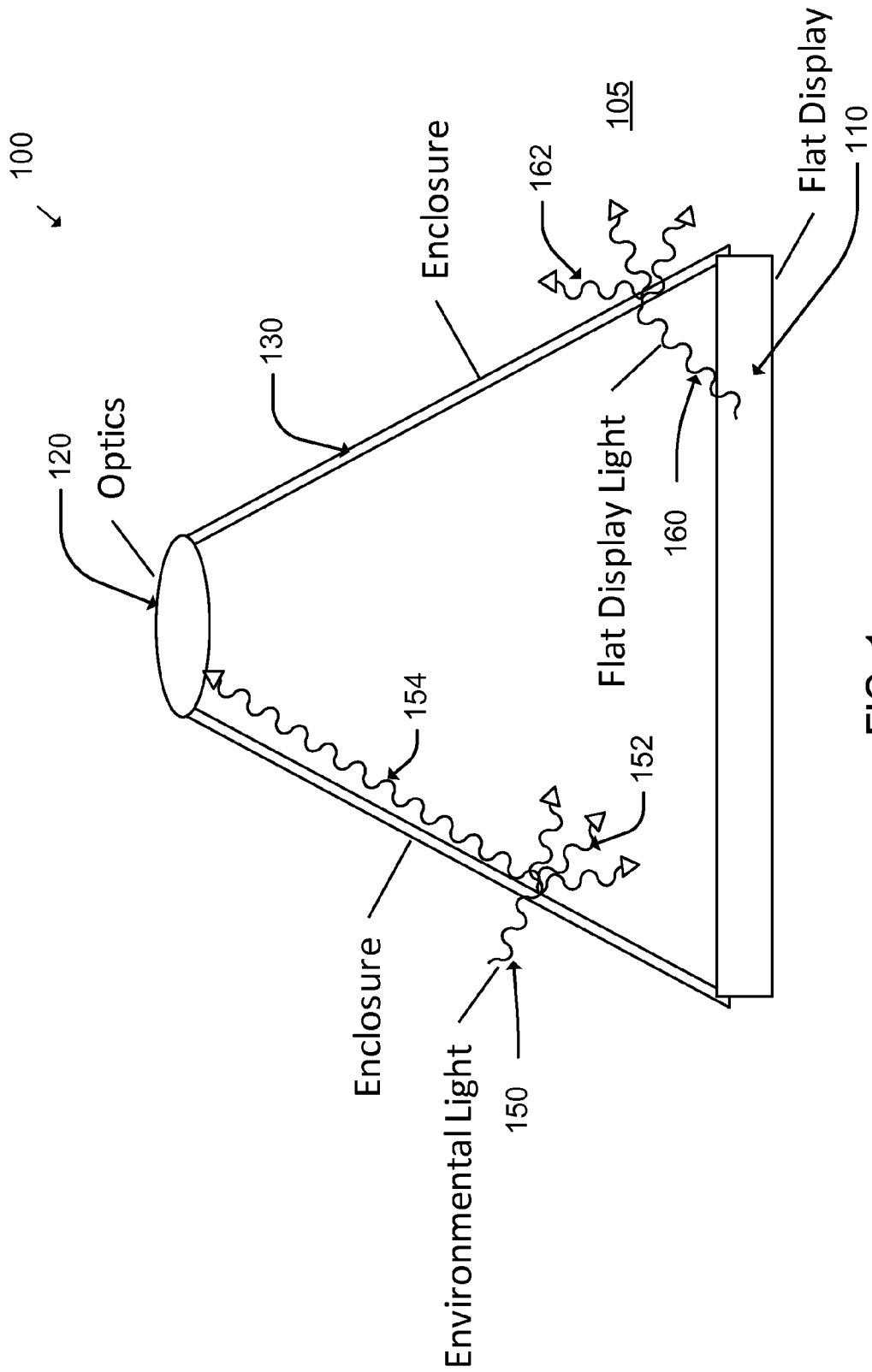

FIG. 1

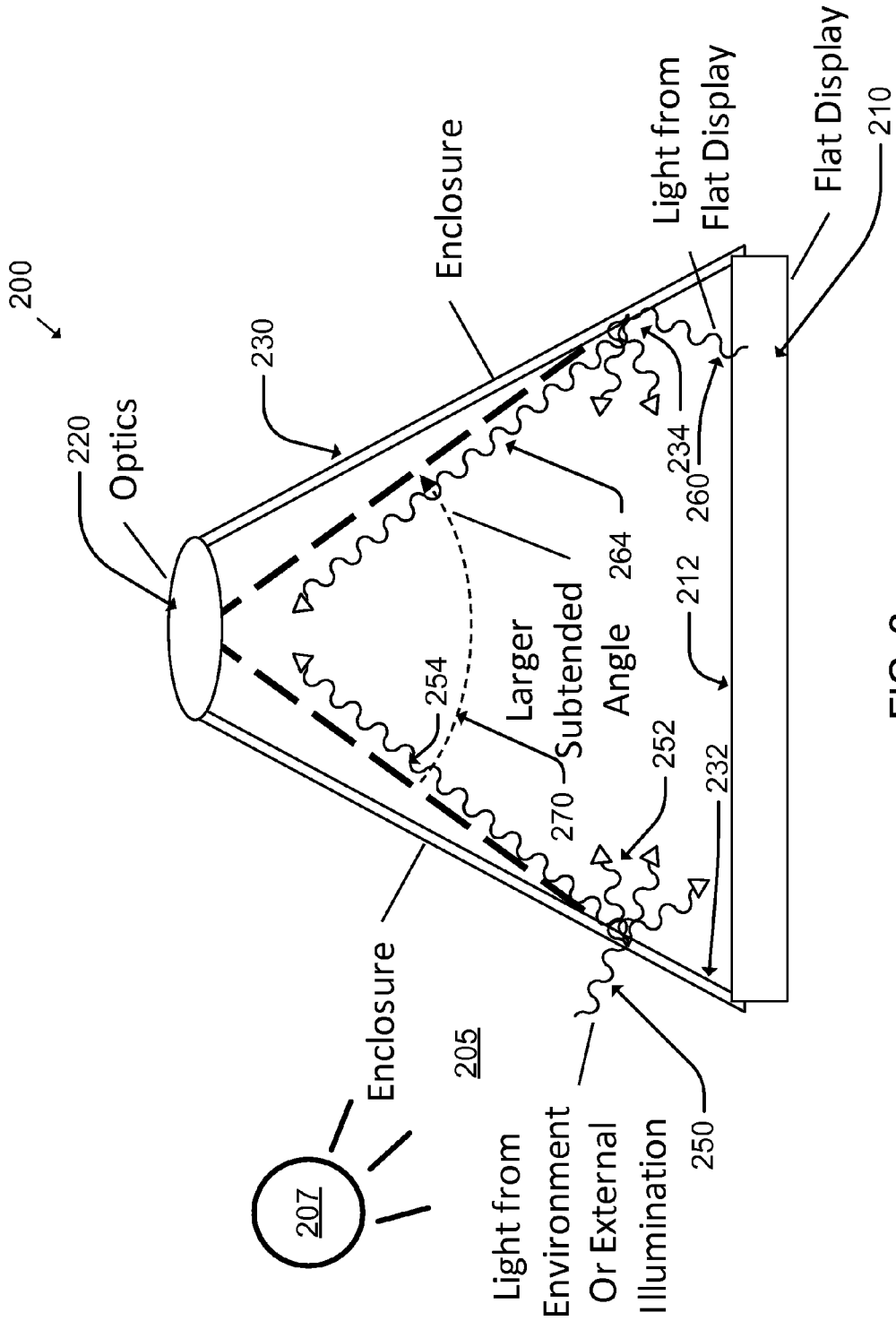

FIG. 2

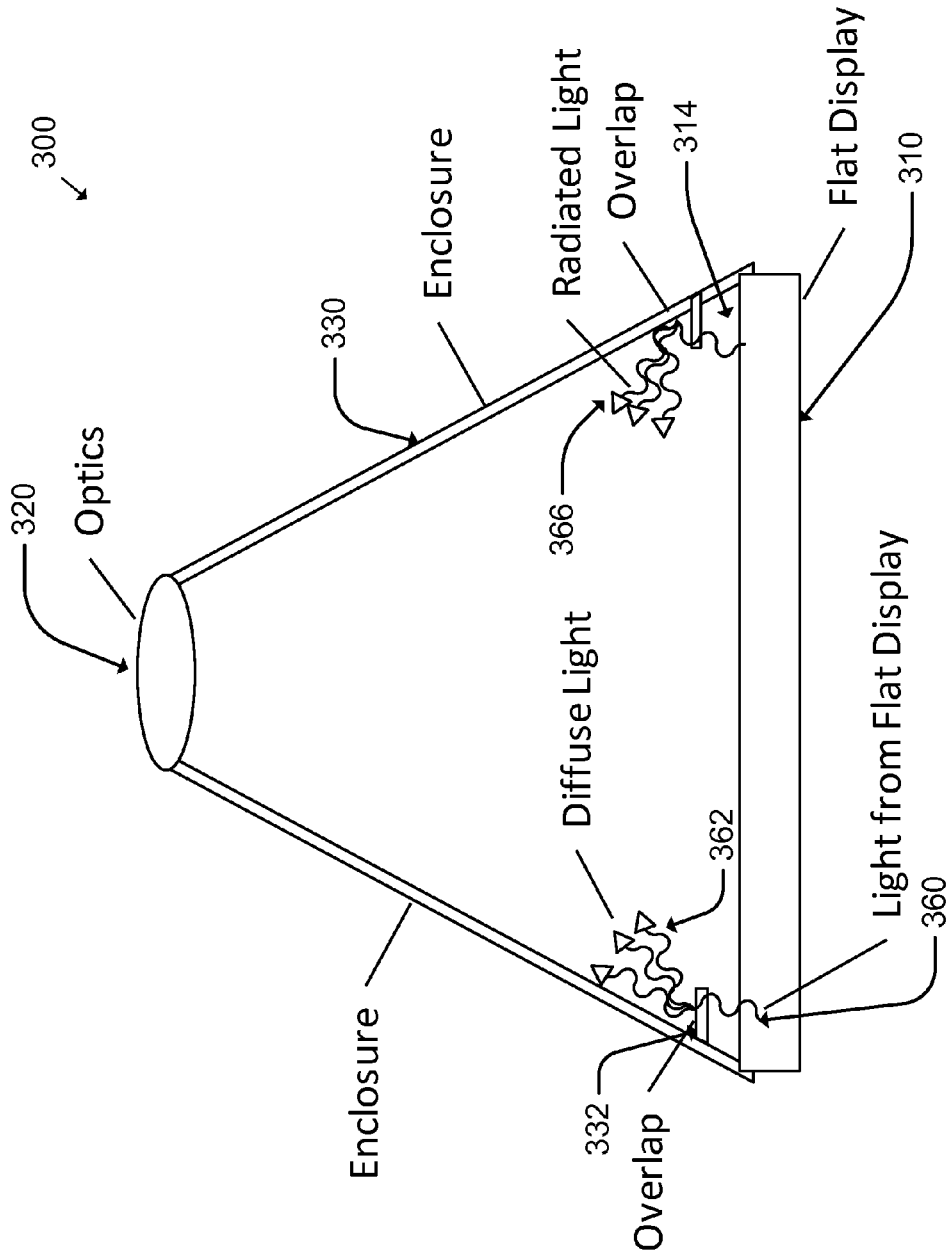

FIG. 3

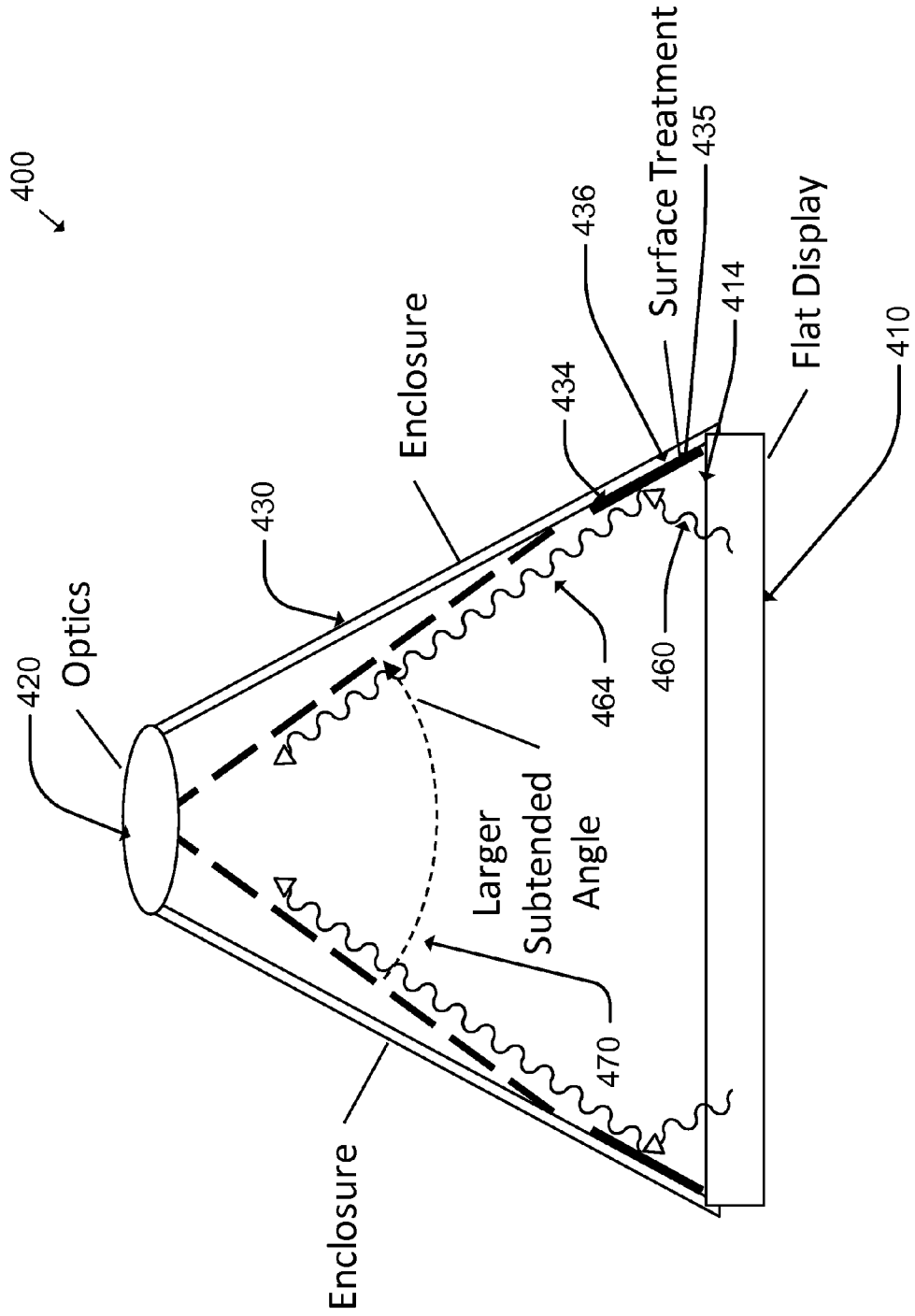

FIG. 4

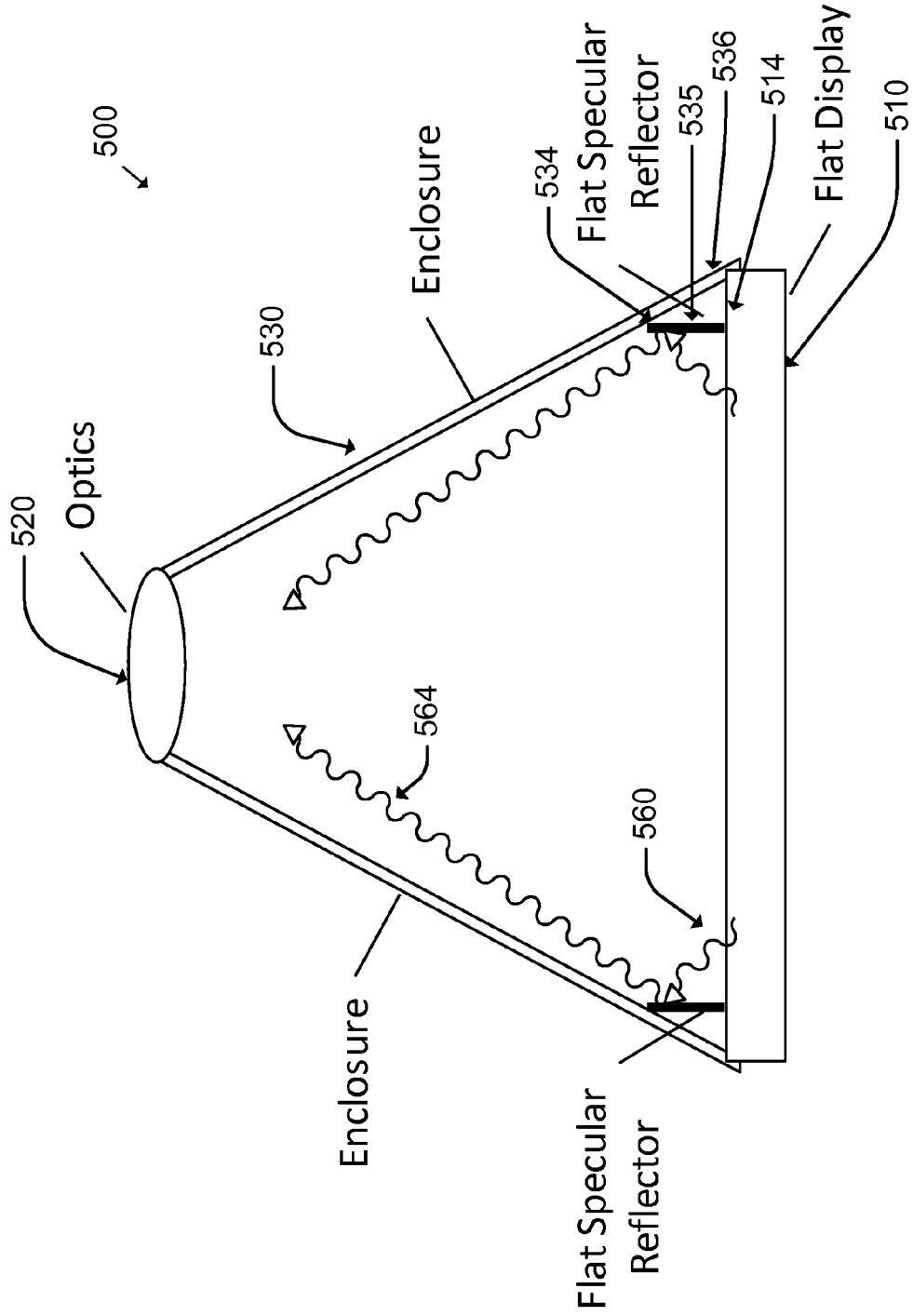

FIG. 5

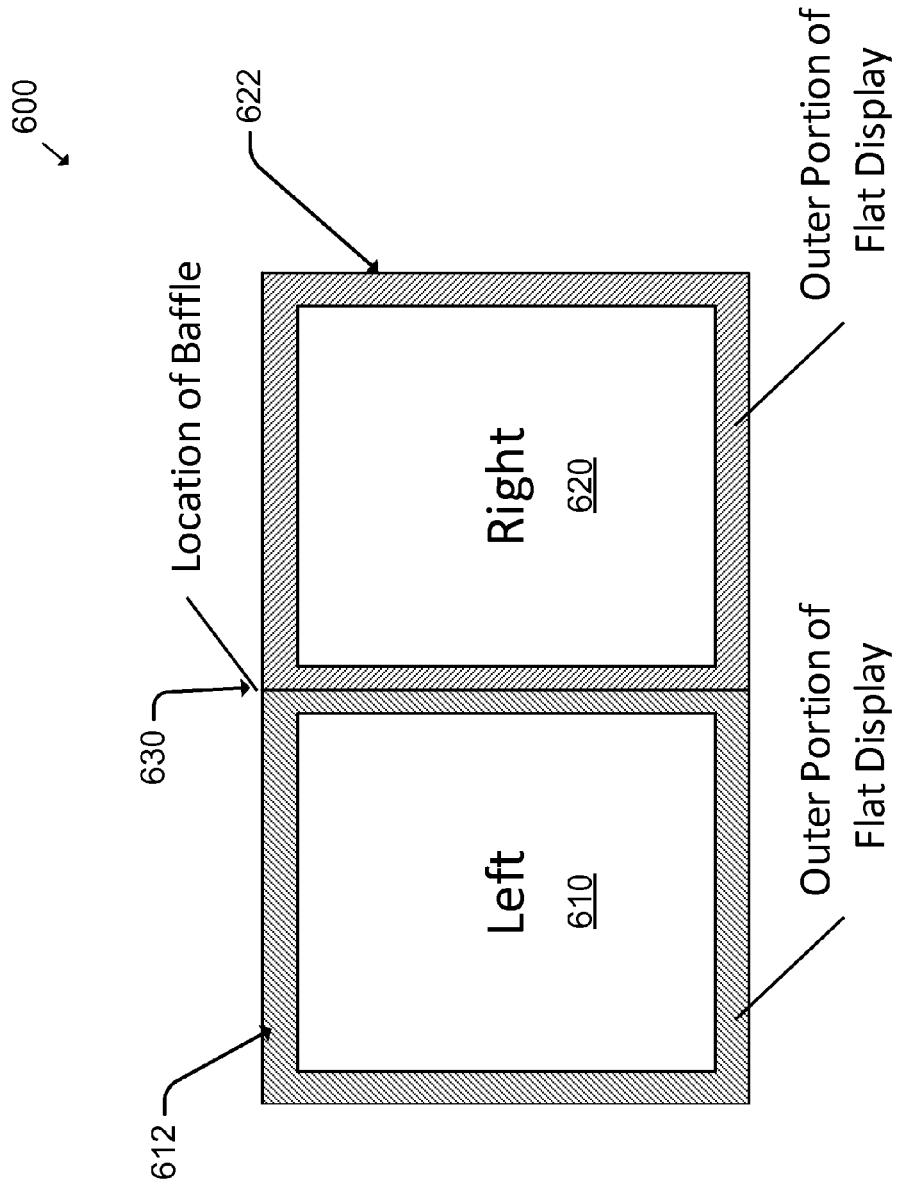

FIG. 6A

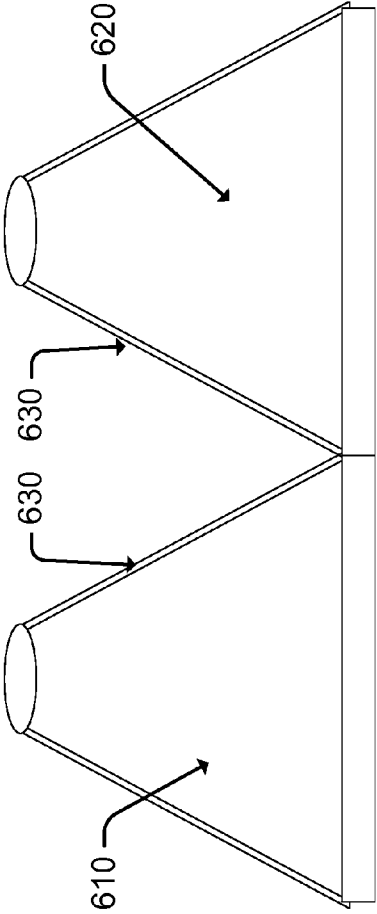

FIG. 6B

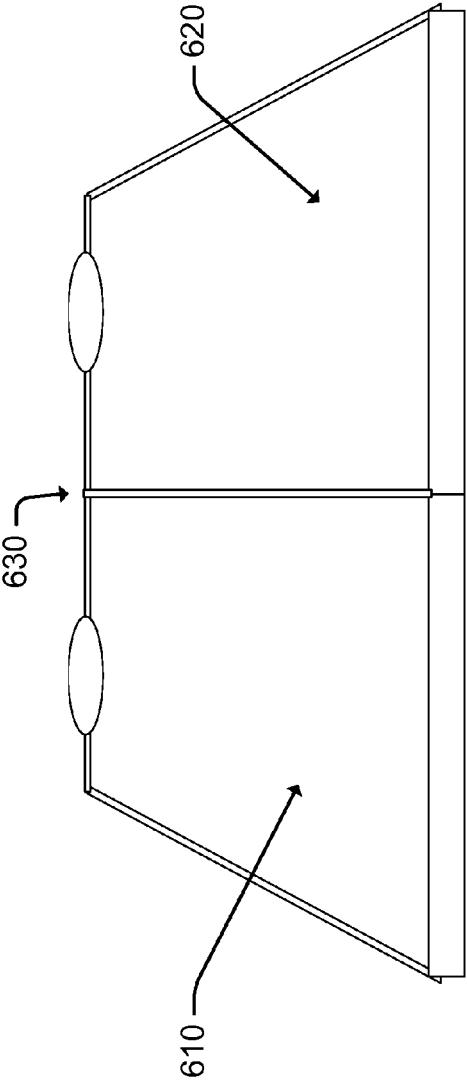

FIG. 6C

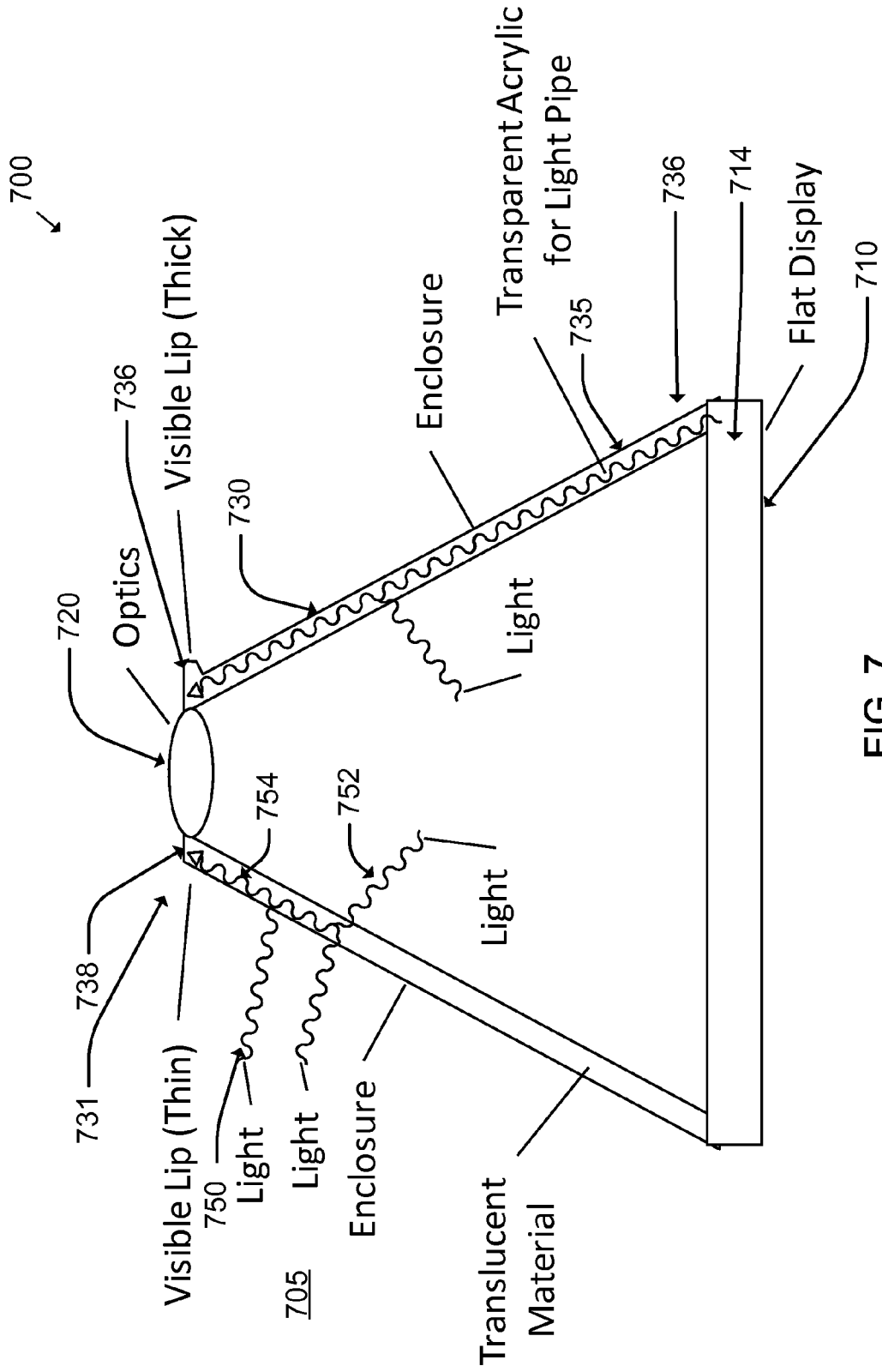

FIG. 7

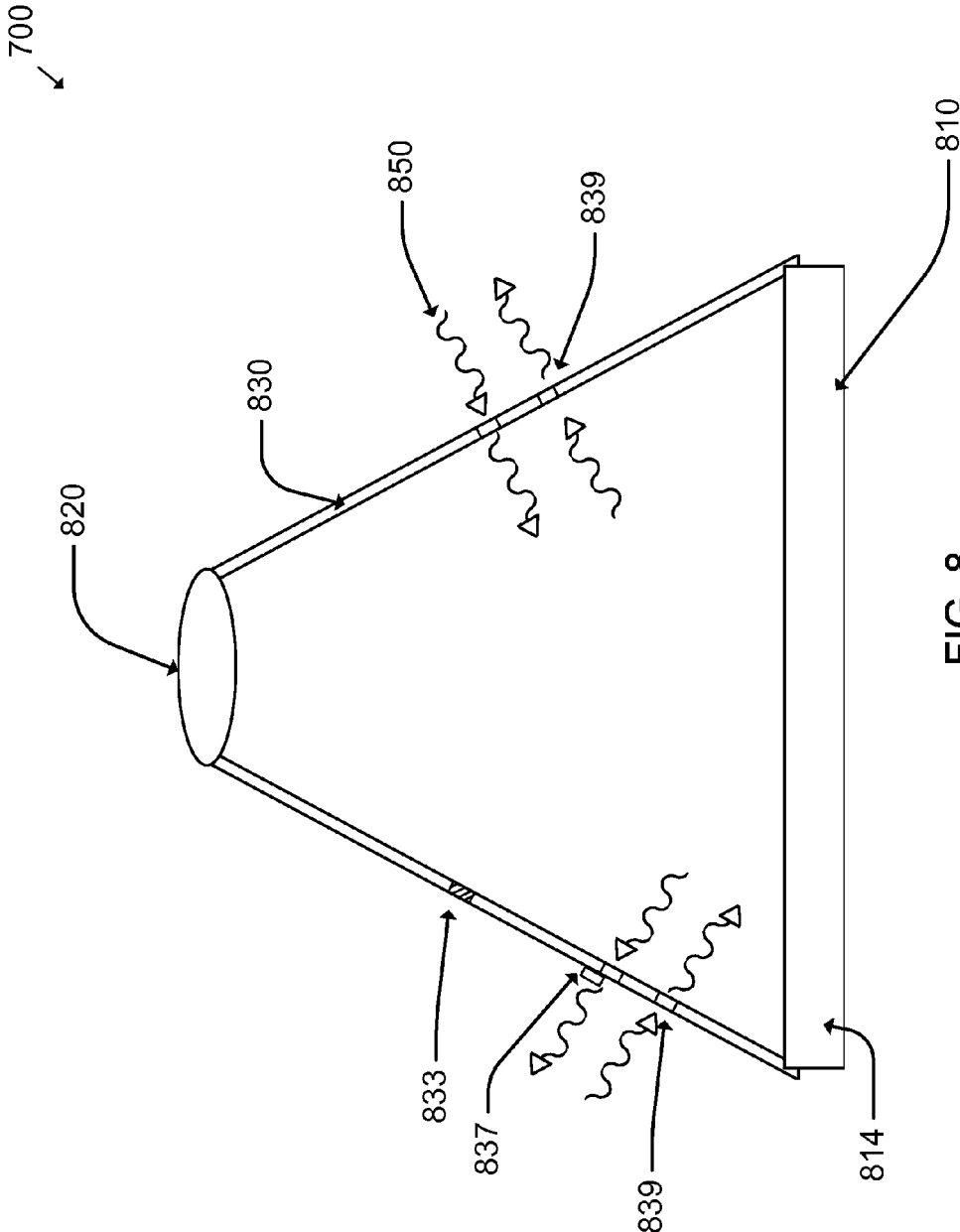

FIG. 8

CONTROL OF AMBIENT AND STRAY LIGHTING IN A HEAD MOUNTED DISPLAY

CROSS-REFERENCE TO RELATED APPLICATION

[0001] This application is based upon and claims priority to U.S. provisional patent application 61/800,866 entitled "Control of Ambient and Stray Lighting in a Head Mounted Display," filed Mar. 15, 2013, attorney docket number 028080-0873, the entire content of which is incorporated herein by reference.

STATEMENT REGARDING FEDERALLY SPONSORED RESEARCH

[0002] This invention was made with government support under Grant No. W911 NF-04-D-0005, awarded by the Army Research Office. The government has certain rights in the invention.

BACKGROUND

[0003] Head Mounted Displays or Head Coupled Displays for Virtual Reality (HMD) typically are composed of a flat display (FD), such as an LCD panel, that is viewed by a user through magnifying optics (optics) that are offset a distance from the FD. This arrangement is typically surrounded by a mechanical enclosure or housing which is designed from an optically occluding material that will block light from the natural environment so that the optics magnify the light from the FD, and not the natural environment, and so that light from the FD is not visible through the sides of the enclosure. The internal portion of the enclosure may also be coated or made from a dark material or treated or otherwise designed to not intentionally reflect internally light emanating from the FD. An HMD can be attached to the user's head, while a head coupled display can be held to the user's eyes, similar to binoculars, without directly attaching to the user's head.

SUMMARY

[0004] Ambient light is used to create a larger perceptual field of view in a Head Mounted Display (HMD). The technique may be of use to emerging HMD vendors. Others try to block all stray light. This invention uses it by controlling it.

[0005] While counterintuitive, this invention has found that there are advantages to breaking the rules of prior approaches and instead to carefully specify the design of the housing in such a way as to control and harness the reflection and diffusion of light from the environment and the FD.

[0006] In one implementation, virtual environment viewing device comprises a display having a display area, an optics component oriented towards the display and having a field of view, and a translucent housing connected to the display and the optics, wherein the field of view is configured to include the display area and a portion of the translucent housing.

[0007] In another implementation, stereoscopic head mounted display comprises a display configured to display a left image and a right image, a left optics component oriented towards the left image, a right optics component oriented towards the right image, a housing connected to the display, the left optics component, and the right optics component, wherein the left optics component is configured to provide a first view of the left image and a first portion of the housing

and the right optics component is configured to provide a second view of the right image and a second portion of the housing.

[0008] In yet another implementation, head mounted display comprises a display for viewing a virtual environment, an optics component oriented towards the display, and a housing connected to the display and the optics component, wherein an exterior portion of the housing is capable of being illuminated from an interior of the housing by the display.

[0009] These, as well as other components, steps, features, objects, benefits, and advantages, will now become clear from a review of the following detailed description of illustrative embodiments, the accompanying drawings, and the claims.

BRIEF DESCRIPTION OF DRAWINGS

[0010] The drawings are of illustrative embodiments. They do not illustrate all embodiments. Other embodiments may be used in addition or instead. Details that may be apparent or unnecessary may be omitted to save space or for more effective illustration. Some embodiments may be practiced with additional components or steps and/or without all of the components or steps that are illustrated. When the same numeral appears in different drawings, it refers to the same or like components or steps.

[0011] FIG. 1 illustrates a virtual environment viewing device having a translucent enclosure according to example aspects of the present disclosure.

[0012] FIG. 2 illustrates a virtual environment viewing device having a translucent enclosure according to example aspects of the present disclosure.

[0013] FIG. 3 illustrates a virtual environment viewing device having overlaps in the enclosure according to example aspects of the present disclosure.

[0014] FIG. 4 illustrates a virtual environment viewing device having an enclosure with surface treatments according to example aspects of the present disclosure.

[0015] FIG. 5 illustrates a virtual environment viewing device having reflectors according to example aspects of the present disclosure.

[0016] FIG. 6A illustrates a cross-sectional view of a virtual environment viewing device according to example aspects of the present disclosure.

[0017] FIG. 6B illustrates a virtual environment viewing device having a baffle according to example aspects of the present disclosure.

[0018] FIG. 6C illustrates another virtual environment viewing device having a baffle according to example aspects of the present disclosure.

[0019] FIG. 7 illustrates a virtual environment viewing device having an enclosure with lips according to example aspects of the present disclosure.

[0020] FIG. 8 illustrates a virtual environment viewing device having an enclosure with windows according to example aspects of the present disclosure.

[0021] FIG. 9 illustrates a virtual environment viewing device having an enclosure with non-planar walls according to example aspects of the present disclosure.

DETAILED DESCRIPTION OF ILLUSTRATIVE EMBODIMENTS

[0022] Illustrative embodiments are now described. Other embodiments may be used in addition or instead. Details that may be apparent or unnecessary may be omitted to save space

or for a more effective presentation. Some embodiments may be practiced with additional components or steps and/or without all of the components or steps that are described.

[0023] FIG. 1 illustrates a virtual environment viewing device **100** including a display **110**, an optics component **120**, and a housing or enclosure **130**. The display **110** may be a flat display (FD), a stereoscopic display, an LCD display, or other display. The optics component **120** may be a lens, or a pair of lenses for stereoscopic vision, or other optical viewing instrument, or may be a hollow portion or portions of the housing **130**, and is oriented towards the display **110**. If light is allowed to diffusely transmit through the enclosure **130**, and the optics component **120** is designed to include such light, the user may be able to see environmental light **150** from the natural environment, which is diffusely transmitted through the enclosure **130** into the peripheral region of the user's view through the optics component **120**. This diffuse, transmitted light or diffused light **154** can improve the experience of using an HMD as it gives the user a feeling of being more aware of the natural environment and potentially gives the impression of a larger viewing angle. Furthermore, allowing display light **160** from the display **110** to be diffusely transmitted out to the environment **105**, has the potential advantage that it allows other people to get a general feeling for what the user of the virtual environment viewing device **100** is seeing. For example, an explosion might be seen by the user of the virtual environment viewing device **100** as a bright white flash, while others in the room would see the outside of the virtual environment viewing device **100** quickly glowing bright. The sides of the enclosure **130** may be curved or bowed inward or outward. The display **110** may also include flexible, curved, or other similar display technologies.

[0024] While counterintuitive, there is an advantage to allowing light to internally reflect off and or glow from the enclosure when coupled with optics designed to take advantage of such light. FIG. 2 illustrates a virtual environment viewing device **200** including a display **210**, an optics component **220**, and an enclosure **230**. The display **210**, the optics component **220**, and the enclosure **230** may correspond to the display **110**, the optics component **120**, and the enclosure **130**, respectively. If the optics component **220** is designed to have a field of view (FOV) **270** that not only includes a display area **212** of the display **210**, but also a portion of the internal surfaces **232** of the enclosure **230**, then allowing display light **260** from the display **210** to internally reflect off, and or glow from, portions **234** of the enclosure **230**, reflected light **264** has the potential advantage of actually or subjectively giving the user the impression of a larger viewing angle, providing a more immersive experience. By diffusing external illumination **250** from the natural environment **205**, and allowing diffused light **254** to reach the user, the user is given perceptual cues that they see a larger viewing angle but they are not given recognizable imagery from the natural environment **205**, as it has been diffused.

[0025] In one implementation, the enclosure **130** or **230** is made from an optically translucent material and the optics component **120** or **220** is designed to have a field of view that not only includes the display area **212**, but also portions of internal surfaces **232** of the enclosure **230**. For example, one implementation may utilize natural ABS filament in a rapid prototyping printer. This plastic is a light cream color and allows the diffuse transmission and reflection of light. Other translucent materials may be used with varying amounts of diffuse transmission and reflection of light from the natural

environment **205** and the display **210**. In this implementation, the optics component **220** may comprise lenses that subtend an angle approximately 15% greater than the angle that would be subtended by the display **210** alone. In other implementations, the optics component **220** may subtend the angle by other appropriate amounts, including less than 15%, or greater than 15% approaching the limit of human visual perception.

[0026] In addition to natural light, light emitting devices such as an electro luminescent panel or light emitting diodes or similar could be added to the exterior of a housing to provide light if the HMD is being used in a dark environment or in any environment in which it is desired to control such lighting. In FIG. 2 this external illumination **250** may comprise light from an external light source or light emitting device **207** and would serve the same role as light from the natural environment **205**. The light emitting device **207** may be driven at a constant brightness, or modulated to reflect changes including dramatic effects in the virtual worlds typically seen on HMDs. The light emitting device **207** may also be located inside the housing.

[0027] FIG. 3 illustrates another implementation of a virtual environment viewing device **300**, which includes a display **310**, an optics component **320**, and an enclosure **330**. The display **310**, the optics component **320**, and the enclosure **330** may correspond to similarly numbered elements in FIGS. 1 and 2. Unlike FIG. 2, where the enclosure **230** meets the edges of the display **210** exactly, the enclosure **330** further includes overlaps **332**, which partially cover outer edges **314** of the display **310** so as to capture and radiate and re-radiate display light **360** due to the translucent properties of the material of the overlaps **332**. Display light **360** from the display **310** is diffused through the overlaps **332**, producing diffuse light **362**. Display light **360** and/or diffuse light **362** may be radiated off the enclosure **330**, producing radiated light **366**. The overlaps can be offset from the display as shown, or touch the display.

[0028] FIG. 4 illustrates another implementation of a virtual environment viewing device **400**, which includes a display **410**, an optics component **420**, and an enclosure **430**. The display **410**, the optics component **420**, and the enclosure **430** may correspond to similarly numbered elements described above. In FIG. 4, at least a portion of an interior surface **434** of the enclosure **430** may be coated or made with a material that diffusely reflects light from the display **410**. Treatment is made to a portion **436** of the interior surface **434** that is nearest to outer edges **414** of the display **410** so that stray and reflected light is minimized while maintaining the reflected light advantage. For example, a surface treatment **435** may be a narrow band of paper can be adhered to the lower portion **436** of the enclosure that is nearest to the display **410** such that light **460** from the outer edges **414** of the display **410** is diffusely reflected, thus providing a glow of light or diffused light **464** that diffusely approximates the image seen at the very outer edges **414** of the display **410**. The optics component **420** is designed to subtend an angle **470** that includes the surface treatment **435**. The housing **430** may be made from either a translucent or non-translucent material.

[0029] FIG. 5 illustrates another implementation of a virtual environment viewing device **500**, which includes a display **510**, an optics component **520**, and an enclosure **530**. The display **510**, the optics component **520**, and the enclosure **530** may correspond to similarly numbered elements described above. In one implementation, a portion of the

interior portion of the housing may be made with a material that specularly reflects light from the FD. In FIG. 5, a band 535 made of mirrored material may be placed along an interior surface 534 of a portion 536 of the enclosure 530 that is nearest to an outer edge 514 of the display 510 such that light 560 from the outer edge 514 of the display 510 is specularly reflected. The term specularly is meant to mean light that is reflected in a specular, or mirror-like, fashion. This specular band 535 can be shaped to enable optical effect beyond a linear reflection, for example it can be curved or bowed to greater exaggerate the apparent field of view by magnifying a portion of the outer edge 514 of the display 510 that can be seen through the field of view of the optics component 520. This band 535 may also be designed to be partially specular or partially diffuse. This band 535 may also be made from materials that do not preserve a mirror-like image but that have specular and other specular-like optical properties such as a reflective hologram. In addition, the housing 530 may be made from either a translucent or non-translucent material.

[0030] An advantage of some implementations is that graphics that are displayed do not necessarily need to be specially rendered to consider the optical characteristics that have been described, as the reflected light will naturally correspond with the light that is nearest to the outer edges of the FD, and this will typically produce advantages described. In other cases, further advantages can be achieved by specifically rendering imagery near the outer portions of the FD which can be designed to take advantage of the optical characteristics that have been described. For example, if it is desired to give the user the experience of an explosion taking place off in the periphery, then the FD can create a bright area near the edge of the FD such that the enclosure will glow with light in that adjacent area. Another example is to render a bright white border around the outside edge of the FD so that the user perceives a brightness around the outside of the FD's field of view. Another example is to render distorted imagery that considers the magnification properties of the described curved or bowed shape or other specular-like optical properties such as a reflective hologram.

[0031] Head mounted displays often require a physical baffle, added as a component of the housing, to be placed along the center of the housing between the left and right optics, to block imagery from the left portion of the FD from entering the right optics, and from the right portion of the FD from entering the left optics. FIG. 6A illustrates a cross-sectional view 600 of a virtual environment viewing device. A baffle 630 is disposed between a left display portion 610 and a right display portion 620. The baffle 630 may be made from translucent material such as natural ABS filament, or from diffusely reflecting material, or from specularly reflecting material, or from material treated in only a portion to be diffuse or specular or any of the other descriptions as described above so that the advantages described are retained. Light from the FD adjacent to the baffle 630 can be employed advantageously if the baffle 630 is intentionally designed to be translucent. The baffle 630 can then be considered as an exterior side of the housing such that the inventive concepts described herein may be applied to the baffle 630 as if it comprises an exterior side of the left display portion 610 and an exterior side of the right display portion 620. In addition, because the baffle 630 may be enclosed within an enclosure, as in FIG. 6C, additional mirrors or lights may be utilized such that the baffle 630 simulates a true exterior wall.

[0032] Alternatively, the housing may be formed of two enclosures where the left display portion 610 may include one enclosure as described herein, and the right display portion 620 may include another enclosure as described herein such that the baffle 630 may comprise two adjoining exterior walls of the two enclosures, as in FIG. 6B. The baffle 630 then forms an exterior side of the left display portion 610 and an exterior side of the right display portion 620 such that the inventive concepts described herein may be applied to the baffle 630.

[0033] In some head mounted display designs, an individual display, such as the left display portion 610 having a left outer portion 612 and a right display portion 620 having a right outer portion 622, are used for each eye. If a single display is used for both eyes, then the term 'outer portions of the FD' or similar also includes the inner portion of the display that is seen by either the left or right eye as the outer portion of that eye's field of view. In other words, the left outer portion 612 and the right outer portion 622 would include a center portion of the display between the left display portion 610 and the right display portion 620.

[0034] FIG. 7 illustrates another implementation of a virtual environment viewing device 700, which includes a display 710, an optics component 720, and an enclosure 730. The display 710, the optics component 720, and the enclosure 730 may correspond to similarly numbered elements described above. While current technology employs flat displays, the term FD may also include flexible and curved displays. The display 710 may be flexible or curved. The enclosure 730 can also provide an apparent increase in the field of view by presenting the user with light that surrounds the optics component 720. As shown in FIG. 7, the virtual environment viewing device 700 utilizes the optical properties of the enclosure 730 as a light pipe, to collect light 752 from the display 710 as well as light 750 from the external environment 705 and have it travel up to an area 731 that immediately encircles the optics component 720, or a visible lip 738 around the optics component 720. The lip 738 may be formed with various sizes. A thinner or narrow lip 738, which may not substantially protrude from the enclosure 730, would deliver a small amount of light. A thicker lip 736, protruding from the enclosure 730 near the area 731, may also be made, so that it is wider than a minimum width needed to hold the optics component 720 so that an even greater area of light is presented to the user's eye. The enclosure 730 can be made of a transparent material such as Acrylic, which should be coated such that it acts as a light-pipe 735 to gather light from the outer portion of the FD and transmit it, as transmitted light 745, up to the visible lip 736. Clear material such as Acrylic can also be used to gather light 750 from the natural environment 705 and transmit it up to the lip 738 or down to lower portions 736 of the enclosure 730 that are near outer edges 714 of the display 710.

[0035] There may be space between the visible lip and the optics, so that the ring formed by the visible lip is larger in diameter or size than the optics.

[0036] FIG. 8 illustrates another implementation of a virtual environment viewing device 800, which includes a display 810, an optics component 820, and an enclosure 830. The display 810, the optics component 820, and the enclosure 830 may correspond to similarly numbered elements described above. The enclosure 830 includes one or more windows 839 that allows light 850 to pass through. The windows 830 may be located near outer edges 814 of the display

810 and may also be located elsewhere along the enclosure **830**. Uncoated clear Acrylic may be used to provide a transparent window **830** in a portion or all of the enclosure, such as along the left and right sides, so that other people that are near the user of the device **800** can get a general feeling for what the user is seeing. Alternatively, the transparent windows **839** in a portion or all of the enclosure **830**, such as along the left and right sides, may be manufactured as physical openings in the enclosure.

[0037] Any form of transparent windows **839** in a portion or all of the enclosure **830**, may be manufactured to provide variable transmission of light into and out of the enclosure **830**. This can be realized through physical coverings **837** that can occlude all, a portion, or no part of the transparent windows. These coverings could be manually operated by a user, or mechanically operated. The variable transmission of light through the enclosure **830** can also be realized through the use of materials **833** that darken or lighten, i.e. provide variable translucency and transparency, in response to various chemical, electrical, or light triggers.

[0038] FIG. 9 illustrates another implementation of a virtual environment viewing device **900**, which includes a display **910**, an optics component **920**, and an enclosure **930**. The display **910**, the optics component **920**, and the enclosure **930** may correspond to similarly numbered elements described above. The enclosure **930** may take different shapes, with the enclosure **930** acting to transfer light in the different ways described thus far, including but not limited to a translucent portion **937**, and a light-pipe portion **935**, as shown in FIG. 9. The enclosure **930** may have non-planar or curved walls **933**. The enclosure **930** may have a protruding portion **932**, forming an angle **963** of, for example, approximately 90 degrees or any other appropriate degree. The enclosure **930** may further have a complementary indented portion **934**, forming an angle **931** of, for example, approximately 120 degrees or any other appropriate degree. The angles **963** and **931** may be determined to focus, collect, redirect, or otherwise transmit internal light **960** and external light **950**, such as transmitted light **962** and diffused light **964**.

[0039] The components, steps, features, objects, benefits, and advantages that have been discussed are merely illustrative. None of them, nor the discussions relating to them, are intended to limit the scope of protection in any way. Numerous other embodiments are also contemplated. These include embodiments that have fewer, additional, and/or different components, steps, features, objects, benefits, and advantages. These also include embodiments in which the components and/or steps are arranged and/or ordered differently.

[0040] Unless otherwise stated, all measurements, values, ratings, positions, magnitudes, sizes, and other specifications that are set forth in this specification, including in the claims that follow, are approximate, not exact. They are intended to have a reasonable range that is consistent with the functions to which they relate and with what is customary in the art to which they pertain.

[0041] All articles, patents, patent applications, and other publications that have been cited in this disclosure are incorporated herein by reference.

[0042] The scope of protection is limited solely by the claims that now follow. That scope is intended and should be interpreted to be as broad as is consistent with the ordinary meaning of the language that is used in the claims when interpreted in light of this specification and the prosecution

history that follows, except where specific meanings have been set forth, and to encompass all structural and functional equivalents.

[0043] Relational terms such as “first” and “second” and the like may be used solely to distinguish one entity or action from another, without necessarily requiring or implying any actual relationship or order between them. The terms “comprises,” “comprising,” and any other variation thereof when used in connection with a list of elements in the specification or claims are intended to indicate that the list is not exclusive and that other elements may be included. Similarly, an element preceded by an “a” or an “an” does not, without further constraints, preclude the existence of additional elements of the identical type.

[0044] None of the claims are intended to embrace subject matter that fails to satisfy the requirement of Sections 101, 102, or 103 of the Patent Act, nor should they be interpreted in such a way. Any unintended coverage of such subject matter is hereby disclaimed. Except as just stated in this paragraph, nothing that has been stated or illustrated is intended or should be interpreted to cause a dedication of any component, step, feature, object, benefit, advantage, or equivalent to the public, regardless of whether it is or is not recited in the claims.

[0045] The abstract is provided to help the reader quickly ascertain the nature of the technical disclosure. It is submitted with the understanding that it will not be used to interpret or limit the scope or meaning of the claims. In addition, various features in the foregoing detailed description are grouped together in various embodiments to streamline the disclosure. This method of disclosure should not be interpreted as requiring claimed embodiments to require more features than are expressly recited in each claim. Rather, as the following claims reflect, inventive subject matter lies in less than all features of a single disclosed embodiment. Thus, the following claims are hereby incorporated into the detailed description, with each claim standing on its own as separately claimed subject matter.

The invention claimed is:

1. A virtual environment viewing device comprising:
 - a display having a display area;
 - an optics component oriented towards the display and having a field of view; and
 - a translucent housing connected to the display and the optics,
 wherein the field of view is configured to include the display area and a portion of the translucent housing.
2. The virtual environment viewing device of claim 1, wherein an internal surface of the translucent housing has a differential surface.
3. The virtual environment viewing device of claim 1, wherein an internal surface of the translucent housing has a reflective surface.
4. The virtual environment viewing device of claim 1, wherein an internal surface of the translucent housing has a diffusive surface.
5. The virtual environment viewing device of claim 1, wherein the display is non-planar.
6. The virtual environment viewing device of claim 1, wherein the display comprises a multiple element display panel.
7. The virtual environment viewing device of claim 1, wherein a translucency of the translucent housing is variable.

8. The virtual environment viewing device of claim **7**, wherein the translucent housing includes a translucent window configured to vary the translucency.

9. The virtual environment viewing device of claim **7**, wherein the translucent housing includes an adjustable opening configured to vary the translucency.

10. The virtual environment viewing device of claim **7**, wherein the translucency is controlled mechanically, electrically, chemically, or through light.

11. The virtual environment viewing device of claim **1**, further comprising an optical element configured to modify external or internal light from the display.

12. The virtual environment viewing device of claim **1**, further comprising a light emitting device.

13. The virtual environment viewing device of claim **12**, wherein a brightness of the light emitting device is variable.

14. The virtual environment viewing device of claim **1**, further comprising a light pipe configured to provide selective illumination.

15. The virtual environment viewing device of claim **1**, further comprising a translucent baffle within the translucent housing.

16. The virtual environment viewing device of claim **1**, wherein the translucent housing is configured to pass a light through the optics component at a subtended angle greater than a subtended angle of a display light from the display.

17. The virtual environment viewing device of claim **16**, wherein the subtended angle of the translucent housing is greater than the subtended angle of the display.

18. A stereoscopic head mounted display comprising:
a display configured to display a left image and a right image;

a left optics component oriented towards the left image;
a right optics component oriented towards the right image;
a housing connected to the display, the left optics component, and the right optics component,

wherein the left optics component is configured to provide a first view, the right optics component is configured to provide a second view, the first view includes the left image and a first translucent portion of the housing, the second view includes the right image and a second translucent portion of the housing.

19. The head mounted display of claim **18**, wherein the housing further comprises a translucent baffle between the left optics component and the right optics component.

20. A head mounted display comprising:

a display for viewing a virtual environment;
an optics component oriented towards the display; and
a housing connected to the display and the optics component,

wherein an exterior portion of the housing is capable of being illuminated from an interior of the housing by the display.

* * * * *